

**DELAWARE
INTERNATIONAL
SPEEDWAY**

Late

Model

Rules & Regulations

2010

The rules and or regulations set forth herein are designed to provide for the orderly conduct of racing events and to establish minimum acceptable requirements for such events. These rules shall govern the condition of all events, and by participating in these events, all participants are deemed to have complied with these rules. NO EXPRESSED OR IMPLIED WARRANTY OF SAFETY SHALL RESULT FROM PUBLICATION OF OR COMPLIANCE WITH THESE RULES AND/OR REGULATIONS. They are intended as a guide for the conduct of the sport and are in no way a guarantee against injury or death to a participant, spectator or official.

The race director shall be empowered to permit minor deviation from any of the specifications herein or impose any further restrictions that, in his opinion, do not alter the minimum acceptable requirements. **NO EXPRESSED OR IMPLIED WARRANTY OF SAFETY SHALL RESULT FROM SUCH ALTERATION OF SPECIFICATIONS.** Any interpretation or deviation of these rules is left to the discretion of the officials. Their decision is final.

The Management of Delaware International Speedway.

DELAWARE INTERNATIONAL SPEEDWAY POINTS BREAKDOWN

MODIFIED & LATE MODEL POINTS FOR HEAT RACE QUALIFIERS

1st Place.....	25 points
2nd Place.....	20 points
3rd Place.....	15 points
4th Place.....	10 points
5th Place.....	5 points
6th Place.....	4 points
7th Place.....	3 points

Leader Bonus (Features Only)

A 10 point bonus will be awarded to any racer that leads a lap during a feature event. (This does not mean 10 points per laps led, it means you would get the 10 points bonus if you lead at least one lap during the feature.)

*Each racer will receive 5 points for track run-in. Transponders **MUST** be on installed and operational.

STREET MODIFIED, MODIFIED LITES & AC DELCO TSS MODIFIED POINTS FOR

HEAT RACE QUALIFIERS

1st Place	20 points
2nd Place	18 points
3rd Place	16 points
4th Place	14 points
5th Place	12 points
6th Place	10 points
7th Place	8 points
8th Place	6 points
9th Place	4 points
10th Place	2 points

POINTS FOR A FEATURE EVENT

1st Place	110 points
2nd Place.....	100 points
3rd Place.....	95 points
4th Place.....	90 points
5th Place.....	85 points
6th Place.....	80 points
7th Place.....	75 points
8th Place.....	70 points
9th Place.....	65 points
10th Place.....	60 points
11th Place.....	55 points
12th Place.....	50 points
13th Place.....	45 points
14th Place.....	40 points
15th Place.....	35 points
16th Place.....	30 points
17th Place.....	25 points
18th Place.....	20 points
19th Place.....	15 points
20th Place.....	10 points
21st Place.....	8 points
22nd Place.....	6 points
23rd Place.....	4 points
24th Place.....	2 points
25th Place.....	2 points
26th Place.....	2 points

TRACK RULES

1. No alcoholic beverages in the pits. Anyone caught will be barred from the pits, 2 weeks first offense; 1 year second offense.
2. Any driver found under the influence will be barred from driving for 1 year from date of suspension.
3. No working on or checking of race car on the track surface. Anyone doing so will be sent to the rear of the pack. Car may be worked on in the infield by driver or track officials only.
4. Anyone not obeying Flagman's signals may be black flagged from race track.
5. Any foul language or unsportsmanlike conduct on the race track will be black flagged to the pits.
6. Any foul language or unsportsmanlike conduct will not be tolerated at the race track.
7. Any person entering another race team pit area for the purpose of causing a disturbance will be barred for 2 wks. 1st offense - 1 yr. 2nd offense. All questions shall be directed to either the Pit Steward or the Del. State Police on duty.
8. "Black Flag" - Report to the pits for consultation. After 1 lap of black flag, the car will not be scored.
9. Any car running in an unsafe or hazardous condition will be black flagged.
10. Any driver getting out of his car to argue or question a call or decision of an official, will be sent to the pits for the remainder of the racing event that night, plus 1 week suspension or one racing event.
11. No fighting in the pits or on the track. First offense is suspension of 2 weeks, second offense is suspension from the track 1 year from date.
12. Any car that is not in his line up position on pit road or if he needs wrecker assistance will line up to the rear of the field.
13. The race will be started by the flagman only. If the lead car jump starts or if he cannot set a sufficient pace, the driver will be warned the first time. If he cannot start at a proper pace, he will be moved to the rear of the field.
14. Any car jumping position before the green flag will bring out a caution and will be sent to the rear of the field. (Repeated jump starts will be black flagged.)
15. Charge Laps
 - A. Heats – There will be a charge lap on the start and on the next to last lap.
 - B. Features – There will be a charge lap on the first half of the feature. No charge lap on second half except on the next to last lap.
16. Accidents - Any car bringing out the caution or left sitting when the caution lights come on will line up to the rear of the pack, including the charge lap.
17. Line up after a caution flag. Line up on last completed lap or tower instruction.
18. After 1 lap has been scored, the starter will line the lead car in his position.
19. Caution Lights - All drivers must immediately bring their car to a slow pace and line up Delaware Start. The 4th corner officials will post positions on message board. Drivers should move immediately to posted positions, if they do not they will be sent to the rear.
20. Any car leaving the racetrack to pit while the race is stopped, will line up to the rear of the pack.
21. When signal from starter shows 1 lap to restart of race, all cars must be in their position. Any car in the infield after this signal will fall to the back of the pack.
22. Any restart with 5 laps or less to go will start single file. A feature event that experiences difficulty to get laps complete may go single file at any time.
23. Any car bringing out or involved in 3 cautions during a Feature race will be black flagged to the pits.
24. When cars enter the pits, a safe speed must be maintained. Any driver found to be driving at an excessive speed or endangering pit persons will be held at pit road for consultation and can be penalized depending on the severity of the infraction.
25. Only car and driver allowed on pit road.
26. Any driver bringing out or involved in 2 cautions during Consi will be black flagged for the event.
27. Any driver that has not signed in on the insurance release form will not be paid for any position he finishes.
28. All protests must be made before the race by the owner or driver only.
29. In case of rain, the event will be considered complete when more than half of the event has been run. The remaining features will be run first on designated rain date.
30. Track Rules - All track rules should be read and understood by all owners, drivers and crew members. This is the responsibility of all crews. Any questions, please feel free to ask before you race.
31. ANYONE THAT FEELS THAT ANY OF THE TRACK CONDITIONS ARE UNSAFE SHOULD LEAVE HIS CAR OUT OF COMPETITION.
32. All classes, no mirrors
33. All classes, head and neck restraint recommended.
34. All bolt on weight **MUST** be painted white with car # & class **CLEARLY** displayed.

SPEEDWAY POLICY REGARDING USE OF/OR POSSESSION OF ILLEGAL DRUGS OR SUBSTANCES

1. **ILLEGAL DRUGS, DEFINITION:** Illegal drugs are those substances defined and prohibited by state and/or federal laws.
2. **GENERAL PROHIBITION:** Possession or use of illegal drugs or drug substances, as defined above, is prohibited in any form, by any participant at Delaware International Speedway, either on the Speedway grounds, or in any area considered to be used in the operation of the Speedway, such as parking lots or leased properties.
3. **PARTICIPANT, DEFINITION:** A participant is any person taking part in any event at Delaware International Speedway in any form, including but not restricted to drivers, car owners, mechanics, crew members, sponsors, track officials or pit area observers. All such persons shall be considered public figures who have, by their own choice, become involved in auto racing events at Delaware International Speedway, with the full understanding that he or she must abide by the rules and regulations established and published or announced by Delaware International Speedway. All participants are considered to be responsible for their personal conduct.
4. **VIOLATIONS AND PENALTIES:** Any person found to be in possession of or under the influence of an illegal drug or drug substance on the Speedway property, as defined above, OR any person who is arrested by duly-constituted authorities and charged with possession and/or use of an illegal drug or drug substances, OR any person who is formally charged by the court of law with illegal drug violations, **SHALL BE SUBJECT TO THE FOLLOWING PENALTIES BY THE SPEEDWAY:**
 - A. Suspension from competition and eviction from the Speedway property, and denial of further entry to the Speedway for a period to be determined by Speedway officials.
 - B. Any participant who is formally charged by a court of law with an illegal drug violation, upon notification to Delaware International Speedway management by that agency, shall be suspended from all forms of participation at Delaware International Speedway until such time as the charges are fully adjudicated through the legal process. Any participant convicted of a formal drug charge by such process of law will be prohibited from taking part in any Delaware International Speedway events for a minimum period of 1 year from date of conviction.
5. **APPEALING AND HEARING:** Any participant suspended for violation of these rules maybe granted an appeal hearing by a board of officials designated by Delaware International Speedway, provided the suspended participant requests such a hearing, in writing, within 14 calendar days of the date of suspension. It is the responsibility of the suspended party to make such a request if any hearing is desired.
6. **REINSTATEMENT:** A participant suspended for violation of these rules, **EXCEPT IN CASE OF PERSONS CHARGED WITH SELLING DRUGS**, may, as the result of a decision reached through the hearing process detailed above, be reinstated, if it is mutually agreed that the participant at his or her own expense -- will produce documentation from a physician licensed within the state, certifying that he or she is drug independent, as a result of random and periodical examinations and urinalysis testing, made at the request of Delaware International Speedway management.
7. **PRESCRIBED DRUGS:** If a participant is using prescription drugs on the advice of a physician, such use must be reported to the chief pit steward or racing director prior to the participant's entry into any Speedway activities. Failure to so notify will subject participant to penalties as described above.

QUALIFYING AND LINE UP PROCEDURES

Modified & Late Model –

1. Qualifying, if 24 cars or less, there will be 2 heat races with 7 cars to qualify from each heat.
 - A. Top 7 cars in each heat qualify. Top 5 cars will be inverted by point average, low to high, the rest of the heat qualifiers will line up behind them in order of finish.
2. If there are 25 or more, 3 heats will be run with 5 cars qualifying in each heat.
 - A. Top 5 cars in each heat qualify. Top 3 cars will be inverted by point average, low to high, the rest of the heat qualifiers will line up behind them in order of finish.
3. Consolation cars will line up behind heat qualifiers in the order they finished.

Crate Model, AC Delco & Modified Lite -

1. Timed hot laps. 2 warm-up laps 3 timed laps. If you bring out a caution, your timing is finished.
 - A. Up to 26 cars – Fastest 10 cars inverted by point avg. low to high. Positions 11-26 fast time to slow time.
 - B. 27 or more – Fast 16 times invert top 10 low to high by point avg. 11 – 16 fast time to slow time 17 – 26 order of “B” main finish.

ALL CLASSES -

1. A driver must race in 3 feature events before he can obtain a point average.
2. Any car that is not signed in at the pit tower will not start their racing event.
3. Any car that is not in his line up position on pit road or if he needs wrecker assistance will line up to the rear of the field.
4. Any driver that is currently in the top ten points standings is allowed one provisional start a year. They may use this provisional start on any night that they do not qualify through the heat races or consolation. This provisional start can only be used on point shows. Max two cars per class. Provisional based on highest 2 drivers in points.
5. Any car or driver changes must be reported to the pit tower officials. Changes must be made before the event. Car must start to the rear of the field. If not reported before event, you will be deducted a maximum of 10 spots from finishing position.
6. Any car(s) that fail to meet post race inspection will be positioned to the rear of their field.
7. A driver may not change cars during race. Example, Heats, Consi, Features
8. A driver can only qualify 1 car per class.
9. A driver can only qualify a second car thru a consi. The 2nd car will disqualify the 1st car.
10. Team cars must be clearly distinguishable from one another and use a different number or letter.
11. Any current year champion will be a guaranteed starter in Del. State Championship race.
12. All classes, there will be a min. point avg. for inverted starts.
13. Any car that qualifies in heat and breaks before the feature is still a qualified car and receives heat points.
14. Any driver banging or crashing into a fellow race car under caution may receive a 1 race suspension or a fine of \$250.00 or both.
15. All classes must have a Raceceiver personal scanner to receive speedway broadcast. Raceceivers must be activated and in use during all events, including warm-ups. It is the responsibility of each race team to make sure Raceceivers are mounted safely in the cars and are in good operational order. Cars competing without working Raceceivers will be subject to fines and/or penalties, at the discretion of race officials. Drivers who do not follow instructions broadcast over the radio channel will be sent to the rear of the field or black flagged.
16. All classes must have AMB Trans x260 Transponder. The AMB Transponder is available thru the track or direct from AMB. All transponders must be registered with the pit tower prior to taking the track.
17. No car can race with rear bumper missing.
18. Make up race - Driver that has qualified can change car and start in qualified position.
19. A Driver may run one (1) class only during regular point shows. Multiple class entries permitted on “Double Entry” nights.
20. One car cannot be entered in two classes at the same event.
21. If there is not a full field, you may start the feature at the rear.

2010 LATE MODEL RULES

Body

- A) The nosepiece style (GM, Ford, Mopar) must match the body style of the car and be the same as the motor used.
- B) Floor boards and firewall must fully cover the drivers area and be constructed to provide maximum safety.
- C) Legible race numbers, at least eighteen inches (18") high are required on each side of the car and on the roof.
- D) Race number(s) must also be displayed on the front nose and rear fuel cell and be a minimum of six inches (6") in height.
- E) No area of the interior of the cockpit can be less than eleven inches (11") below the roof and the roll cage for safety and easy exiting of car from either side measured straight up and down.
- F) Side windows must have fifteen inches (15") minimum opening, measured at an angle to the door.
- G) Dropped interiors may begin no further forward than the rear engine plate with a maximum of four inches (4"), and cannot drop below four inches (4") of the rear of the hood. The start of the dropped interior may not be open, as this forms part of the fire wall. The entire width must be closed off in sheet metal.

Driver Compartment

- A) A full metal firewall must encompass the driver's compartment from front to rear, on both sides and the floorboards. Aluminum or sheet metal is required.
- B) This seat must incorporate a padded headrest.
- C) All cars must have a quick-release type steering wheel.
- D) All cars must have a working starter, operated from inside the car.
- E) No mirrors are permitted.
- F) A substantial rock guard steel screen must be mounted in front of the driver to protect him from flying debris, and rocks.

Frame

- A) All frames must be of steel construction and must be a minimum of two inches by two inches square (2"x2"), with a minimum material thickness of .083 inches. If a round tube frame is used, the tubing must have a minimum of one and three quarter inch (1.75") outside diameter, with a minimum material thickness of .083 inches. These frames must use 4130 Chromoly Steel or DOM for construction.
- B) All cars must have a device such as cable, chains, etc. so vehicle may be picked up by wrecker.

Roll Cage

- A) Cars must have a suitable steel roll cage in the drivers compartment
- B) Should the drivers seat not have a suitable right side padded headrest, or right side head net, one must be attached onto the roll cage.
- C) Side roll bars are mandatory and must extend into the door panels.
- D) A minimum of three bars must be used on the left side of the car. Each bar must be a minimum of one and one half inch (1.5") in diameter with a minimum thickness of .095.
- E) The roll cage must be welded to the frame.
- F) The roll cage must be above the driver's helmet.

Transmission

No direct drives are permitted. The transmission must be bolted to the engine, and must have forward and reverse gears and must be able to shift to forward or reverse with engine running. All cars must be self starting.

Drive Shaft

Strap must be bolted or welded to the frame or body of car. Strap should be 2" wide, 360 degrees and 6" behind front U joint. Drive shaft to be painted white.

Rear End

- A) Any type of rear end differential is permitted.
- B) No live axle rear ends are permitted.
- C) No independent rear suspension is permitted.
- D) Only floater wide five hub assemblies are permitted.

Brakes

All cars must be equipped with a four wheel disc braking system.

Wheels Tires

Tires cannot be siped, grooved or treated. All Tires will be stamped DIS. American Racer Tires will be track tires for 2010. Tire size 13" wide max., 92" max. circ. Right rear 29.0/11.0-15 DTW, SD48. All other tires are SD44 or harder. Max tire hoop width is 16.75 in.

Engine

- A) Only V8 engines will be permitted with no limit on cubic inch displacement.
- B) Engines must be based on a factory design and must be naturally aspirated. Aluminum or steel blocks are permitted.
- C) Magnetos are permitted. However, the engine must have an operating self starter.
- D) The engine is permitted to be set back a maximum of twenty five and one half inch (25.5") from center of the ball joint to the front of the motor plate/engine bell housing flange.
- E) The carburetor is limited to 1 four barrel unit.
- F) All engines are limited to one spark plug and two valves per cylinder.

Fuel

Gasoline or alcohol allowed. No nitrous oxide systems allowed. No fuel injection system or electrical fuel pumps or any type of pressurized fuel system is permitted. Only mechanical or belt driven fuel pumps are permitted. No fuel, oil or water lines may run through drivers compartment.

Fuel System

- A) All cars must have fuel cells. The fuel cell must be in a completely enclosed, in minimum 20-gauge steel or 0.060. Aluminum, container. The entire container must be visible.
- B) The fuel cell must be securely mounted behind the rear axle between the rear tires, a minimum of four inches ahead of the rear bumper, no lower than the quick change housing. It must be mounted with a minimum of two .125 inch thick steel straps two inches wide around the entire cell. Cells mounted in a square tubing frame are permitted. All cells must be securely mounted to the frame. The bolts used to mount the fuel cell must be a minimum of 7/16.
- C) The fuel pick up must be on the top or right side of the fuel cell, be constructed of steel and must have a check valve in case of roll over.

Exhaust

- A) Any header that routes through firewall must be sealed off from driver's compartment. Muffler required. Max. 100 db at 25 feet.
- B) The exhaust is not permitted to be directed towards the ground. (The exhaust must be parallel to the ground so as to disturb as little dust as possible.)
- C) All headers must end with a collector.

Weight

- A) Any attached weights must be securely attached to frame below the decking, painted white and have the car number clearly displayed on them. Weights of up to 50 pounds must be secured by two half inch Grade 5 bolts on two weight clamps. Weights secured by one bolt and/or held on by a means other than accepted by the Tech Inspector will not be permitted. No all thread will be permitted. Due to the high risk factor involved, any car that loses lead weight during an event may be fined or face disqualification. Clamp around weights are permitted.
- B) No weights may be attached to rear bumper.
- C) The total weight of the car with the driver must not be less than 2300 track scale pounds.

Transponders

All cars must be equipped with AMB transX 260 transponders. These should be securely attached on the rearward side of the right side motor plate as close to the ground as possible. These may be rented for the event at registration. The burden is on the competitor to ensure that the transponder has fresh batteries or is fully charged, is securely mounted, and is in a suitable position. If a competitor does not have his or her own transponder, one may be rented.

Radio

All drivers must be equipped with an approved one way radio scanner or Racciever which can be purchased at the track.

Shoulder Harness

A 5 point quick release shoulder harness required securely mounted to the frame of the car.

Safety others

- A) There must be no sharp or protruding edges in or around the cockpit, which would impede the driver's rapid exit from the car.
- B) A headrest (behind the head) with padding is recommended.
- C) A right head net in the absence of a padded right headrest is recommended. Head nets must be equipped with quick release mechanisms.
- D) There must be a marked electrical kill switch in reach of driver.
- E) There must be a marked fuel shut off valve in reach of driver.
- F) Recommended all drivers wear a clean one-piece approved driver's suit, quilted or with underwear, head socks, gloves, foot socks and shoes.
- G) An undamaged Snell SA95 or newer spec full face helmet is mandatory for all events including track packing.
- H) Recommended all crews carry an operable fire extinguisher of 20 pounds marked with the car number in 2 inch numbers/letters in the rear of their transporter, capable of extinguishing gas and oil fires.
- I) Neck collars or similar restraints are suggested.
- J) Arm restraints are suggested.
- K) Flame retardant seat, roll bar, knee and steering pads or padding are recommended.

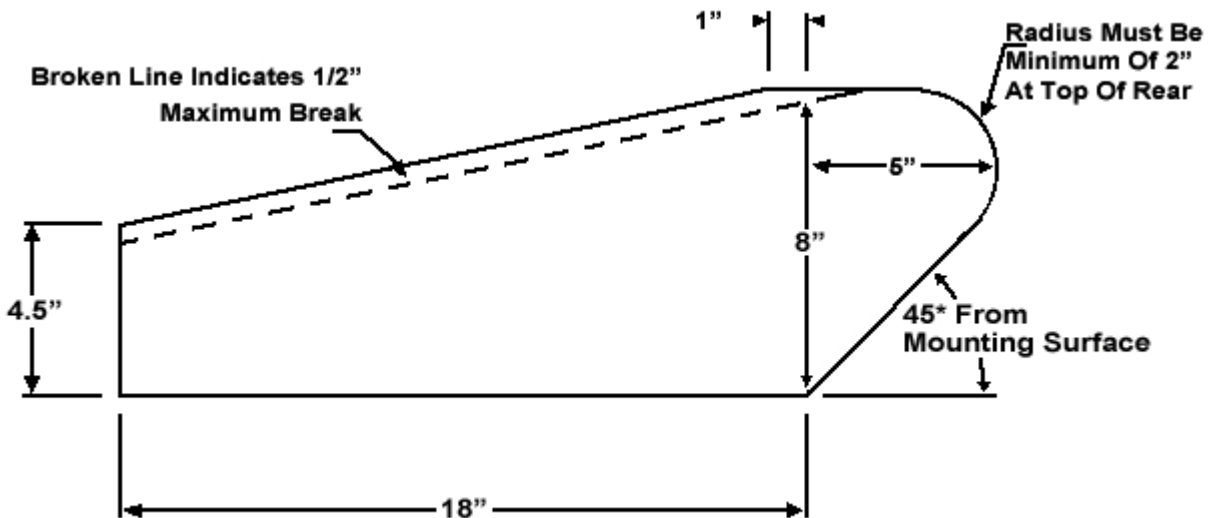

No more than three (3) spoiler supports permitted. Front edge of supports must be in line

Dimensions Have Zero Tolerance

1. Stock nosepiece can extend a maximum of fifty-two inches (52") from center of hub to farthest point extending forward.
2. Roof height must be between forty-five (45") and forty-eight inches (48") from the ground.
3. Front fenders cannot exceed thirty-seven inches (37") in height measured from the ground.
4. The front fender flares may not be higher than fenders by more than two inches (2").
5. Doors cannot exceed thirty-seven inches (37") in height measured from the ground.
6. Fifty-two inches (52") maximum center of rear hub to top corner of quarter panel.
7. Forty-eight inches (48") maximum length from center of rear hub to end of quarter panel.
8. Thirty-eight inches (38") maximum height from top of deck to ground.
9. Minimum of two inches (2") tire clearance from body.
10. Any skirting cannot extend beyond the quarter panel.

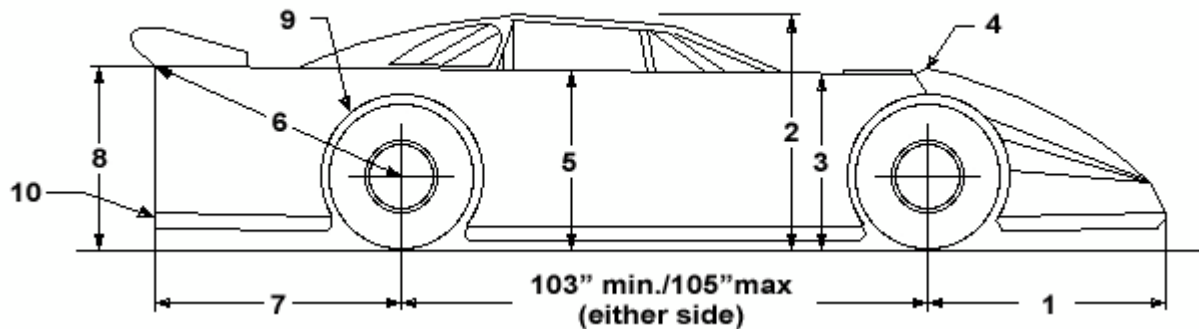

- A. Roof length must be a minimum of forty-four inches (44") to a maximum fifty-four inches (54").
- B. Roof width must be a minimum of forty-eight inches (48") to a maximum fifty-two inches (52").
- C. All roof side panels must extend to edge of decking.
- D. Front fender flares cannot extend beyond front tire more than one inch (1") in width with the wheels pointed straight.
- E. Door cannot exceed seventy-six inches (76") in its entirety at top of door.
- F. Door cannot exceed eighty-two inches (82") in width at the bottom in the center of car.
- G. The quarter panels cannot exceed seventy-six (76") in width at any point behind the center of the rear hub as measured at the top.
- H. Rear decks must taper from seventy-six inches (76") as measured at the top over the rear hubs, uniformly back to seventy-two inches (72") at the spoiler, equally on both sides.
- I. Maximum spoiler width is seventy-two inches (72").

